

HARDING
AUTOPARK SYSTEMS



SPEC SHEET

CARPARX™ VTS-2

Two-Level Dual-Platform
Vehicle Transport System

CARPARX™ VTS-2

The Harding Autopark Systems CARPARX™ VTS-2 (Vehicle Transport System) is a first-of-its-kind hydraulic lift system designed for transporting vehicles from street level to subterranean parking areas below grade. The system has been expressly designed for private residences and small commercial applications where valuable vehicles need to be safely transported to underground motorcourts or parkades for storage or display.

The Carparx VTS-2 inground vehicle transport system is the most popular lift of its type currently sold in North America. Based on a powerful and reliable single scissors design, the VT-2 incorporates a second platform that serves to fill the opening at the grade level when the machine is lowered into the sub basement area. The upper platform system employs a patented telescope design that allows the platform to separate from the lower platform as the lower platform is lowered into the basement. This design creates a new level of safety and security in homes where an open hole in the floor of the garage creates a safety risk or design obstacle for the homeowner. The second platform also provides a permanent parking place at grade level when the VTS-2 is lowered in to the basement.

CARPARX VTS-2 is a safe, cost effective way to move vehicles from one level to another, while both minimizing design challenges and creating additional parking. While not designed for commercial “vehicle elevator” applications or for large multi-family dwellings, it is extremely effective for low-volume vehicle transport applications in private home, estates, boutique hotels, or small multi-family dwellings. Floor-to-floor transport distances normally vary from 9' to 12'. The VTS system is strictly an unmanned system and is not intended for transporting people or for transporting vehicles with passengers aboard.

Designed and built in North America, the Harding Autopark Systems CARPARX VTS-2 can be customized to meet the exacting demands of our client's projects. Four standard length/width units are offered with custom versions available. Each VTS-2 system is build-to-order and installed by Harding Autopark Systems at each client location.



CARPARX™
VTS-2

Standard VTS-2 Unit
234/226 Version

FIG. 1
RAISED POSITION

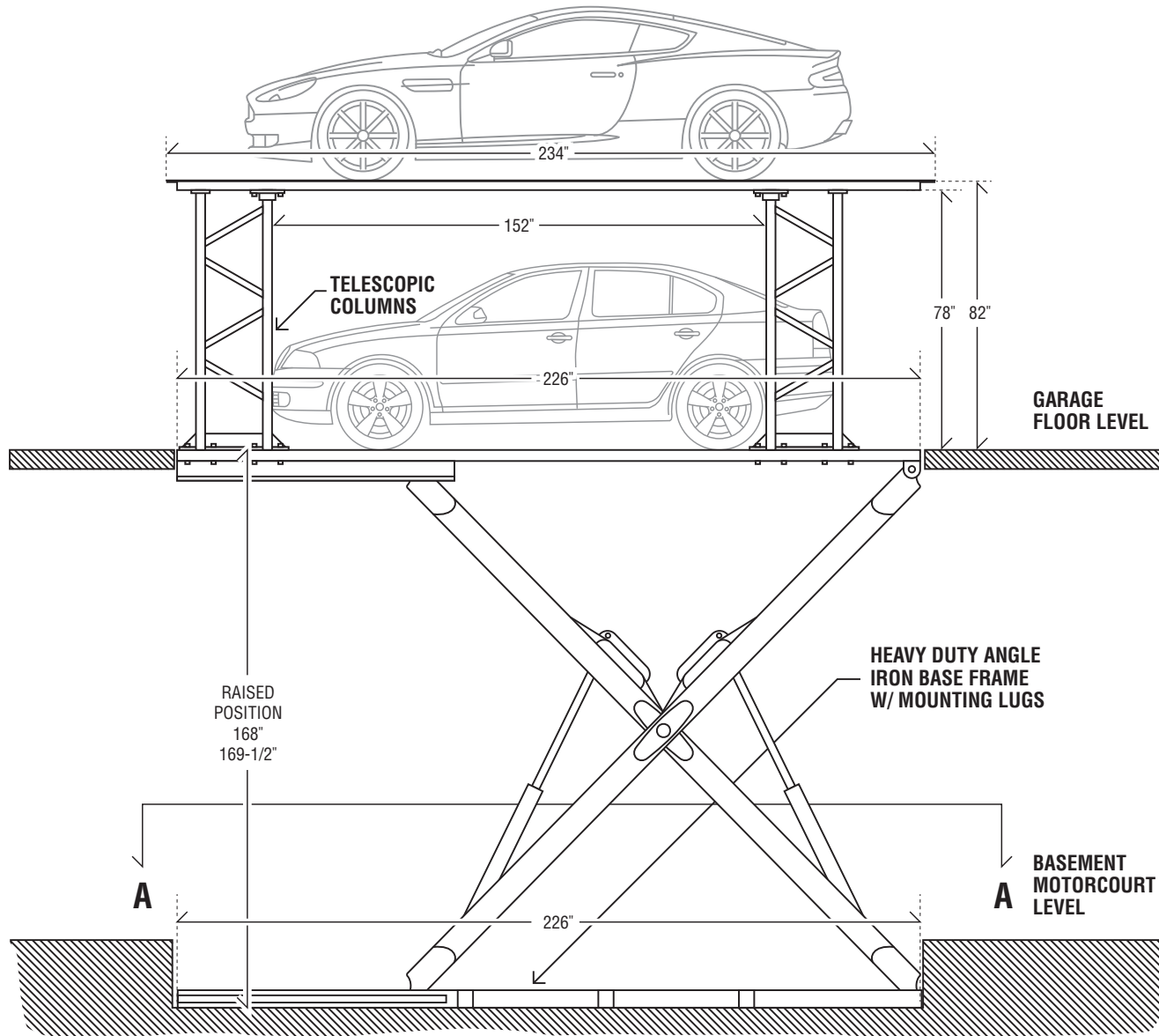

FIG. 2
2 LOWERED POSITION

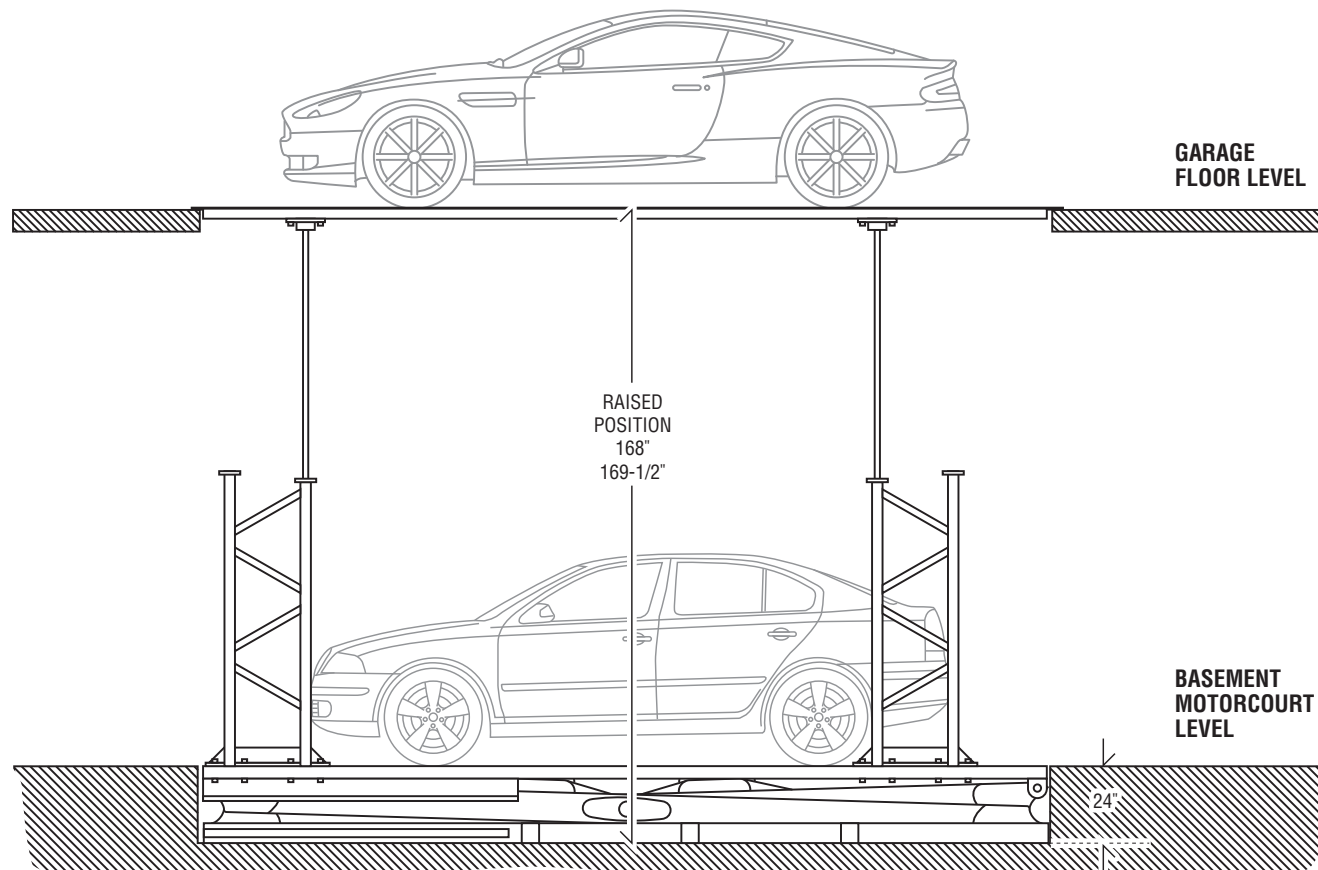
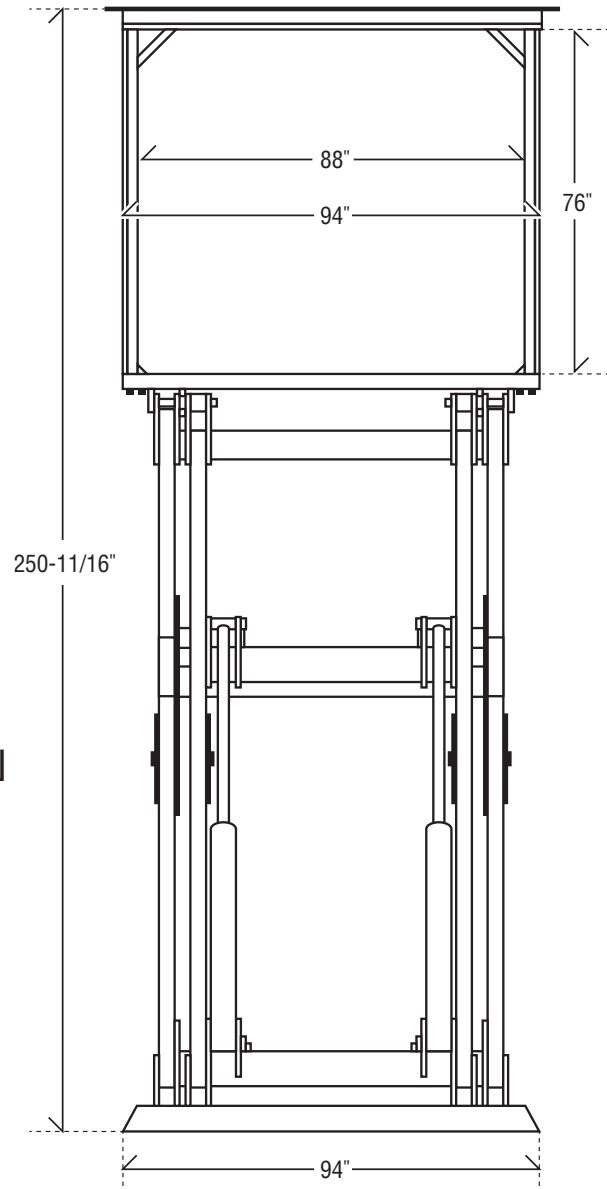

FIG. 3 RAISED POSITION
END VIEW



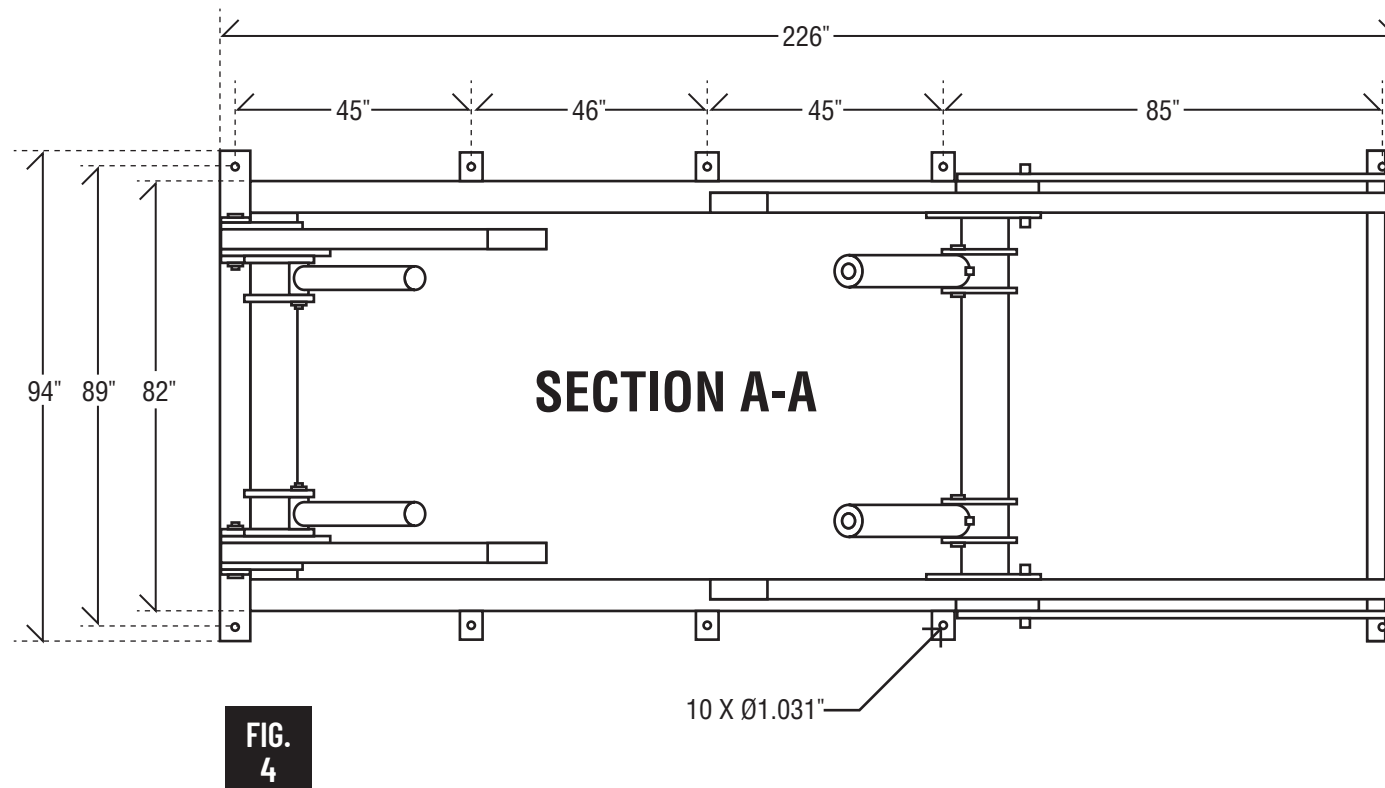

FIG. 5
RAISED POSITION

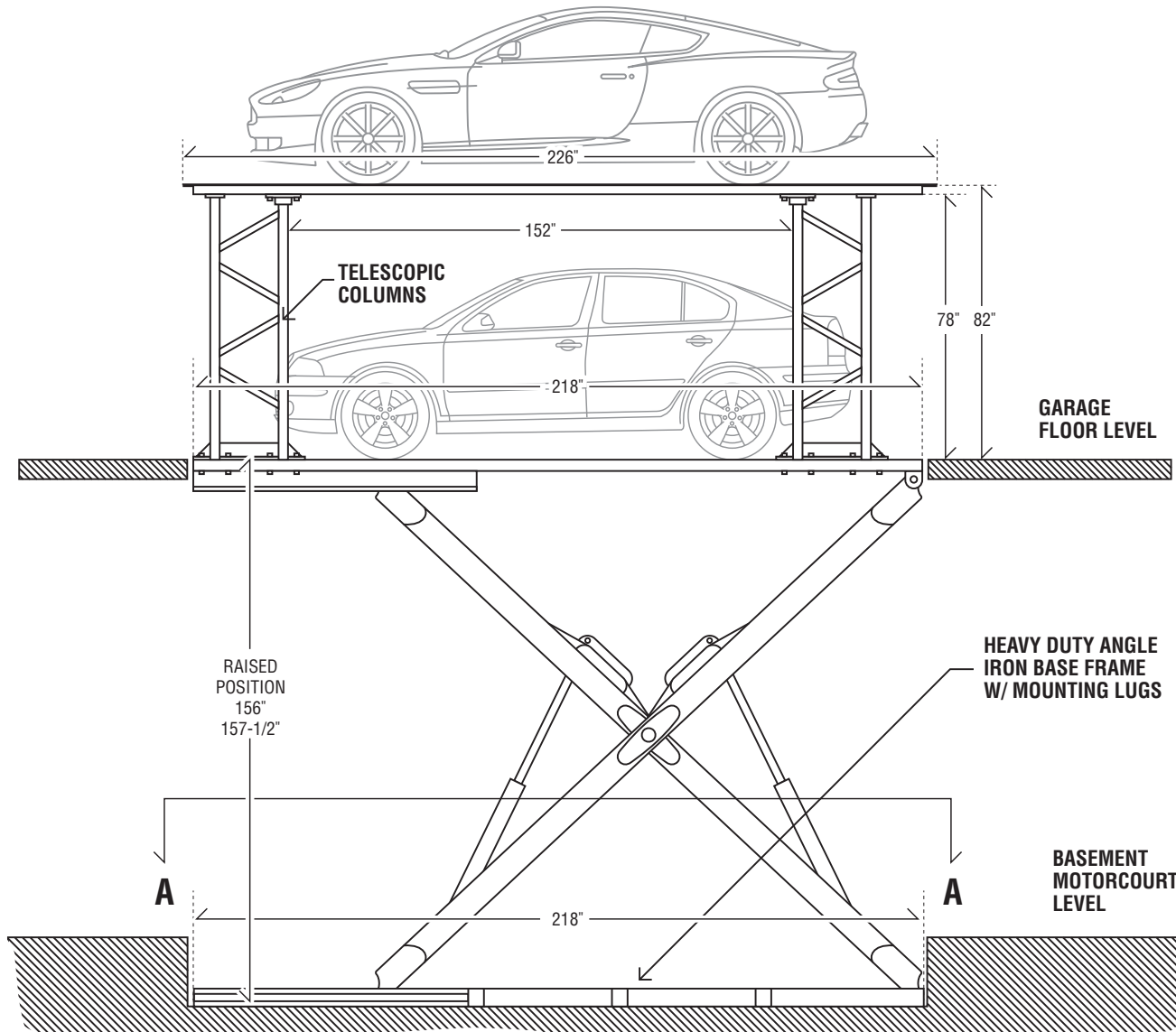
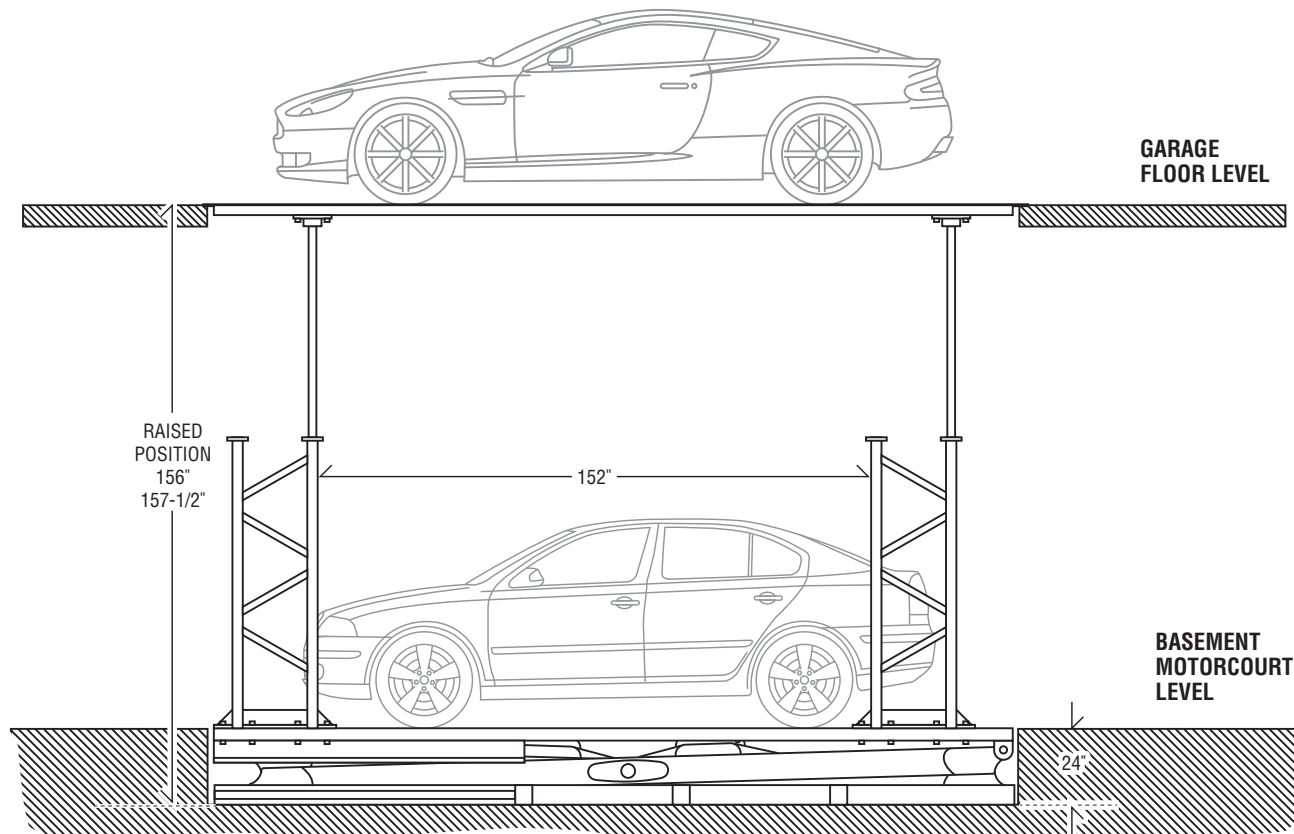

FIG. 6
6 RAISED POSITION



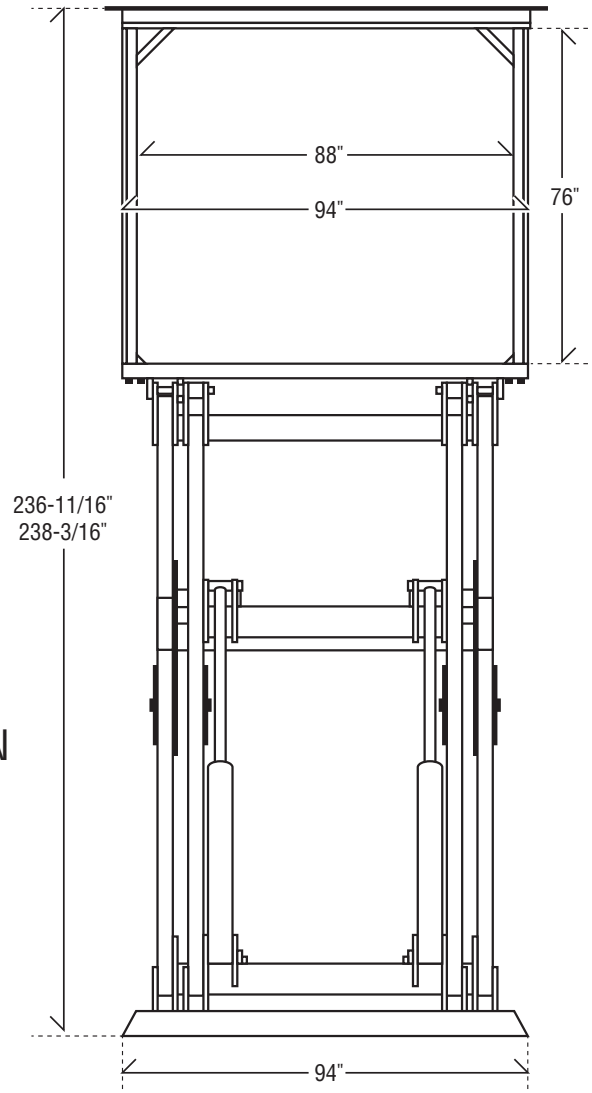

FIG. 7 RAISED POSITION
END VIEW

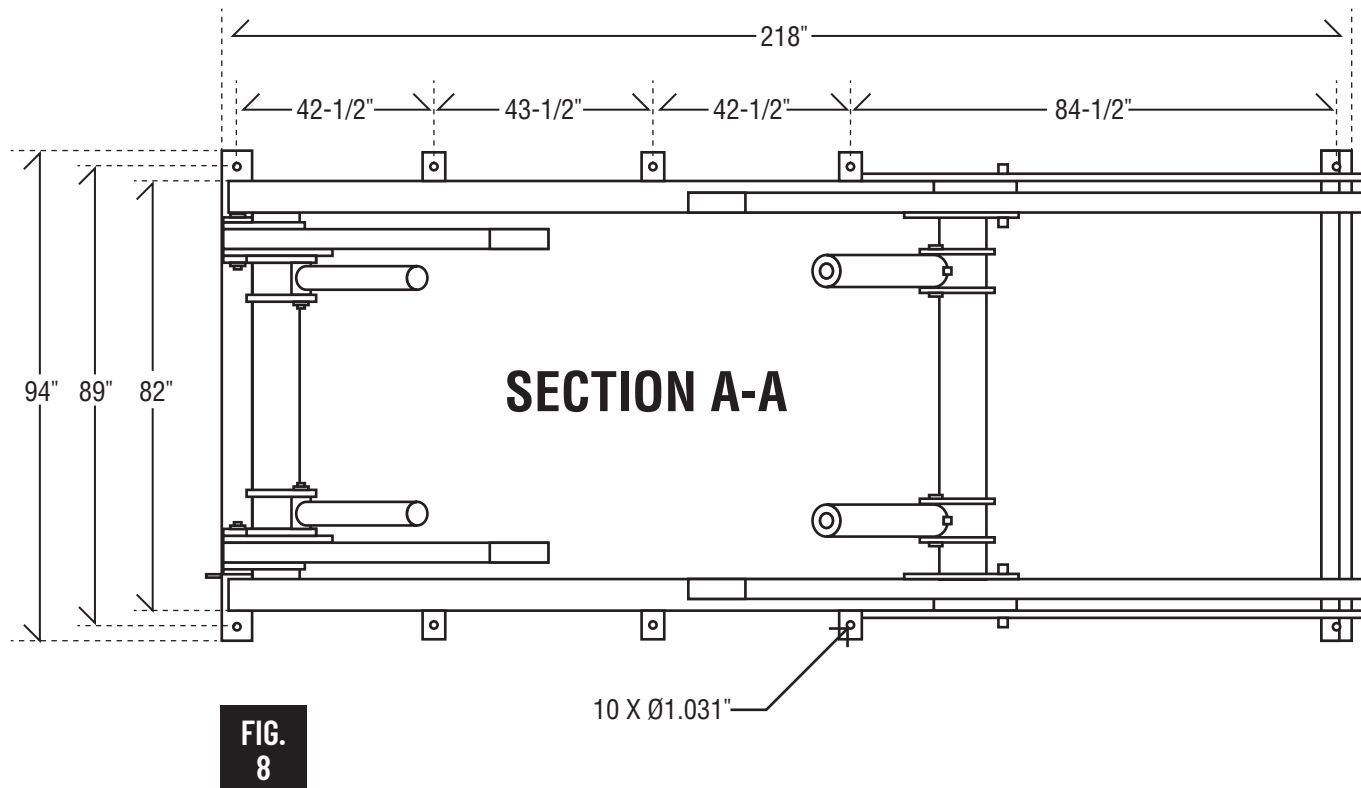

FIG. 9 RAISED POSITION

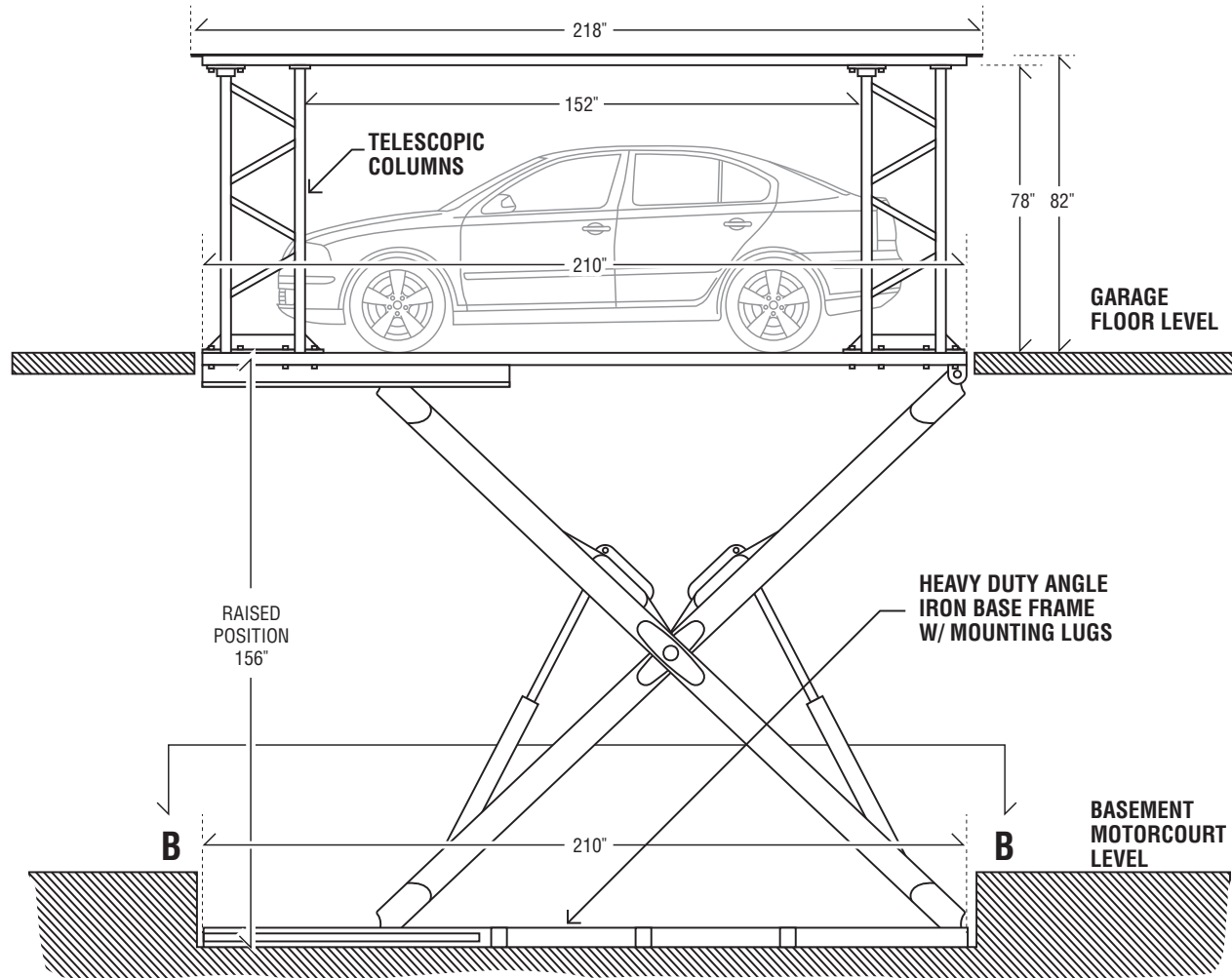
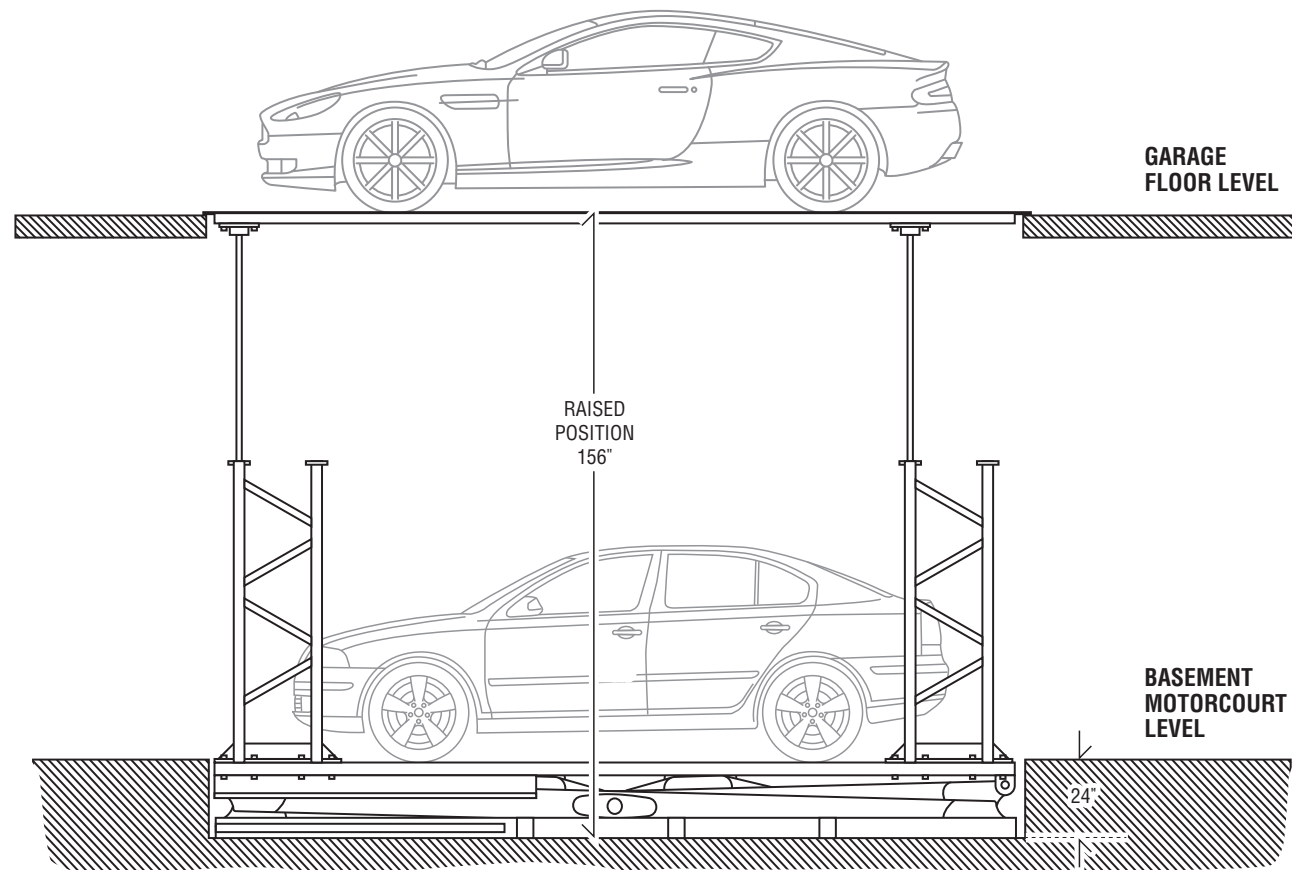

FIG. 10 LOWERED POSITION



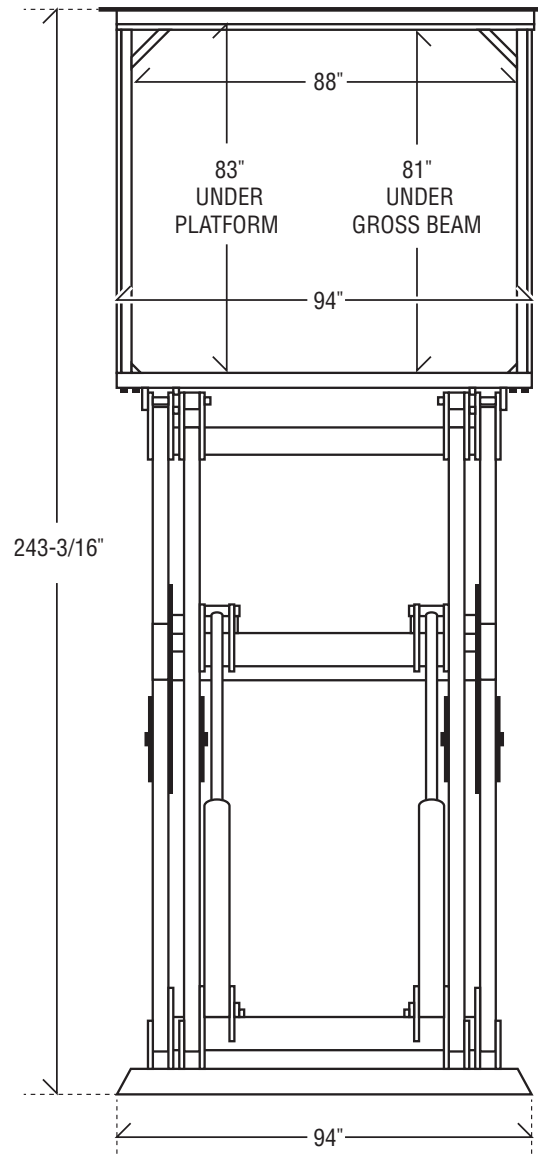
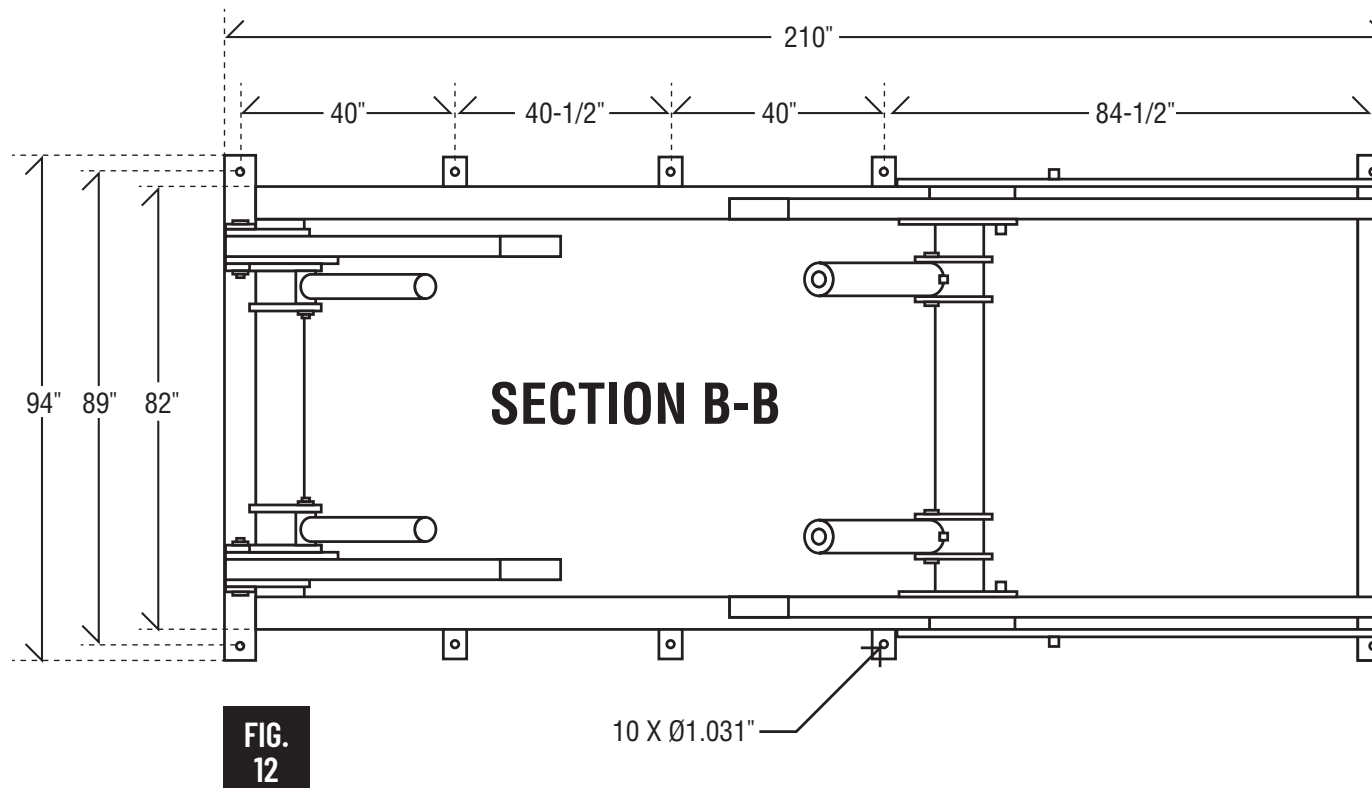

FIG. 11 RAISED POSITION
END VIEW



CARPARX™
VTS-2

Extra Long VTS-2 Unit 242/234 Version

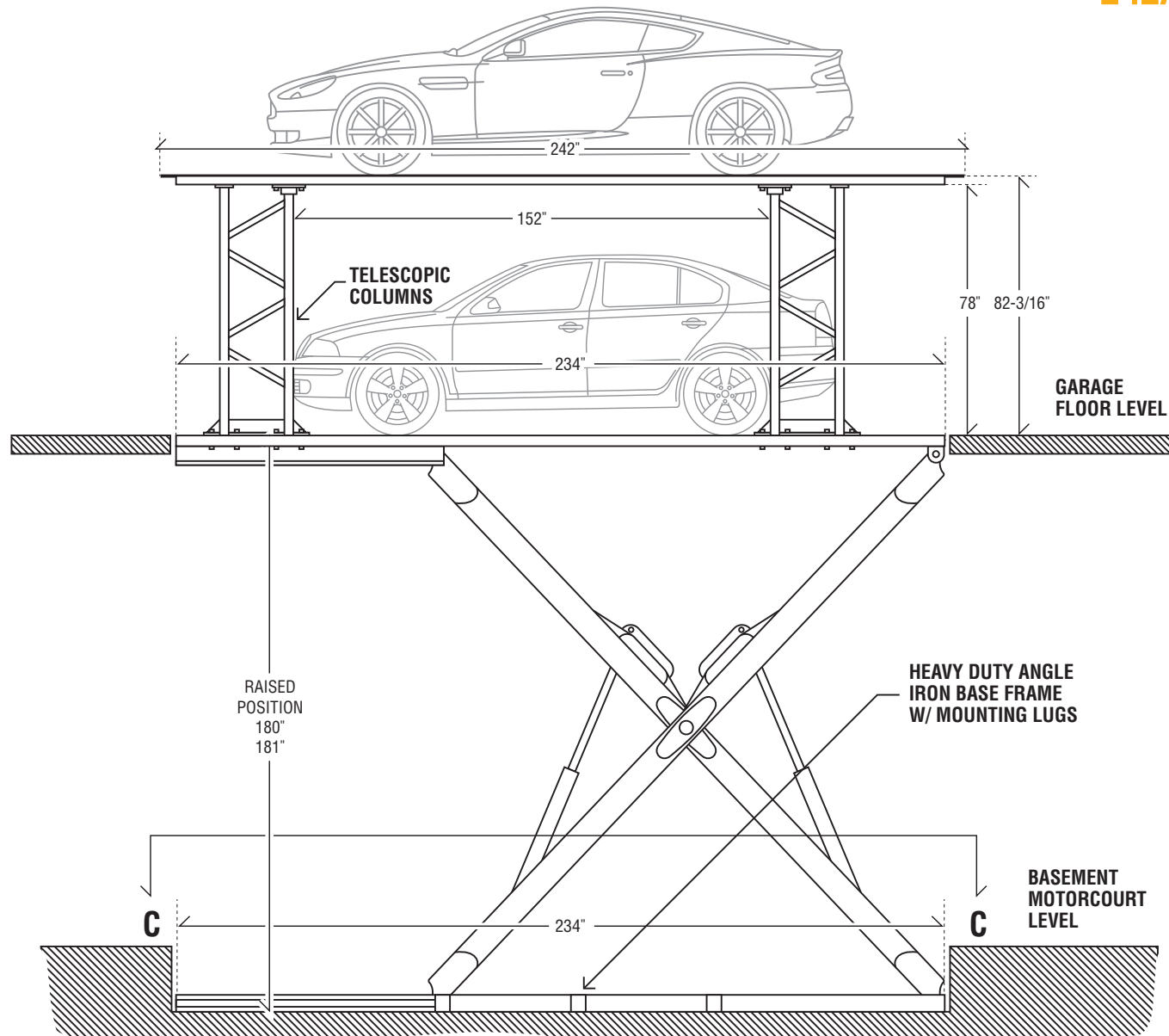

FIG. 13 RAISED POSITION

FIG. 14
LOWERED POSITION

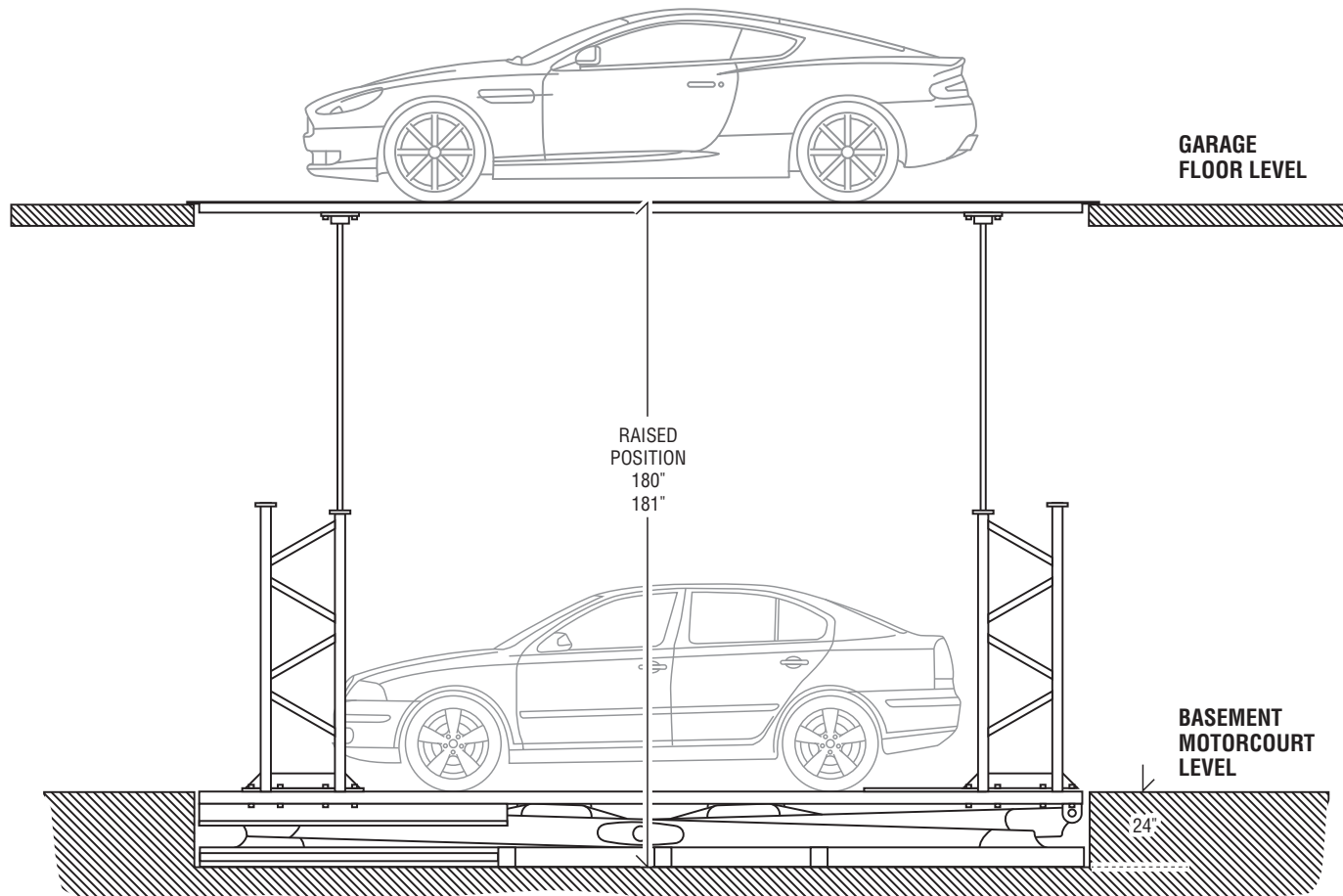
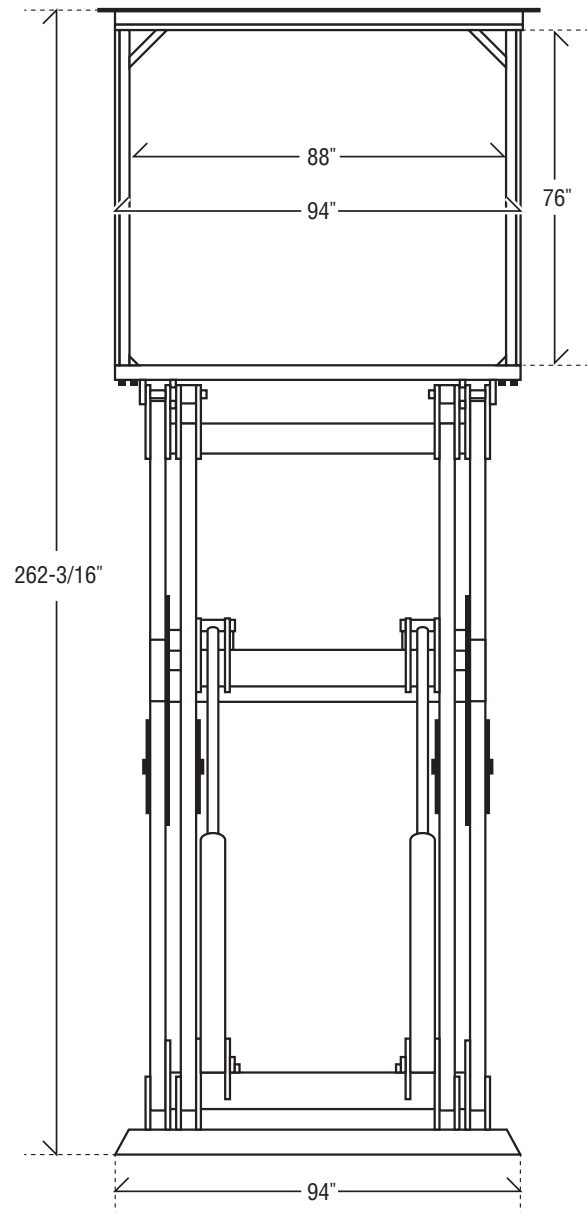

FIG. 15 RAISED POSITION
END VIEW



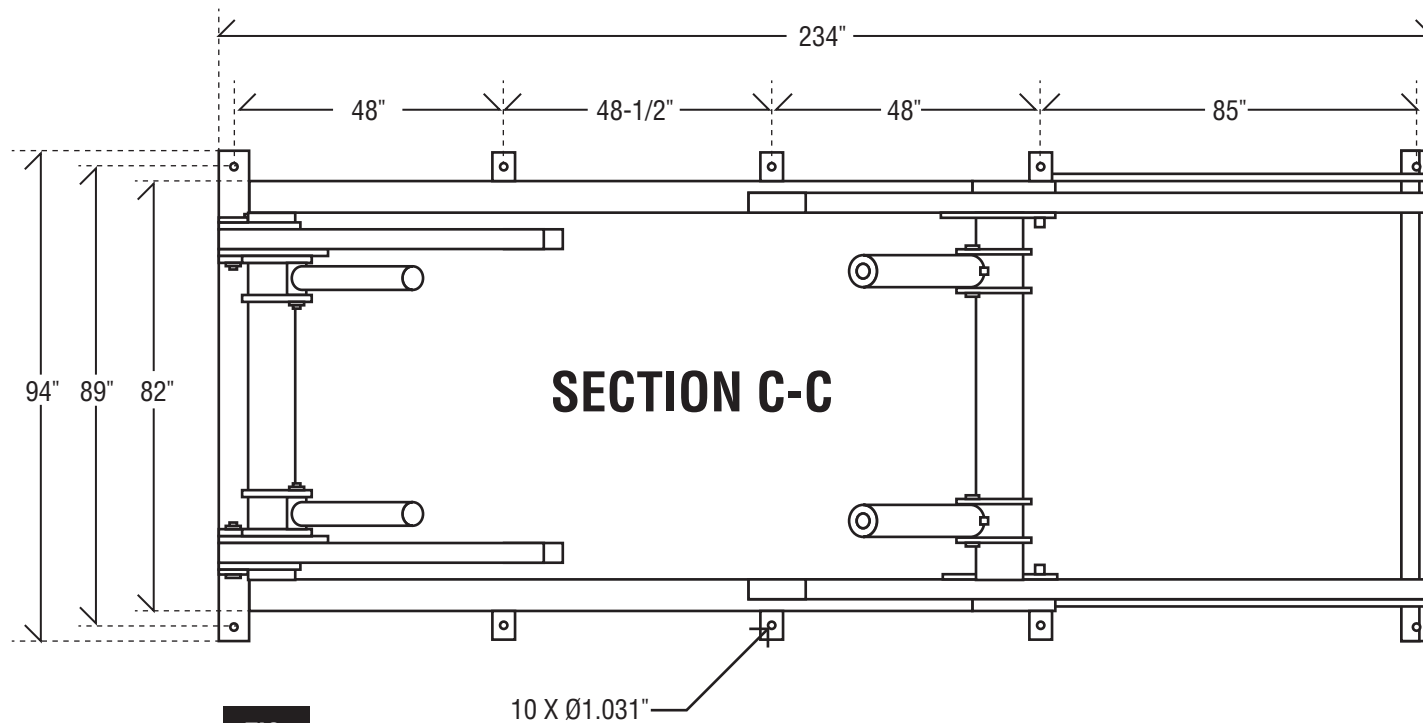
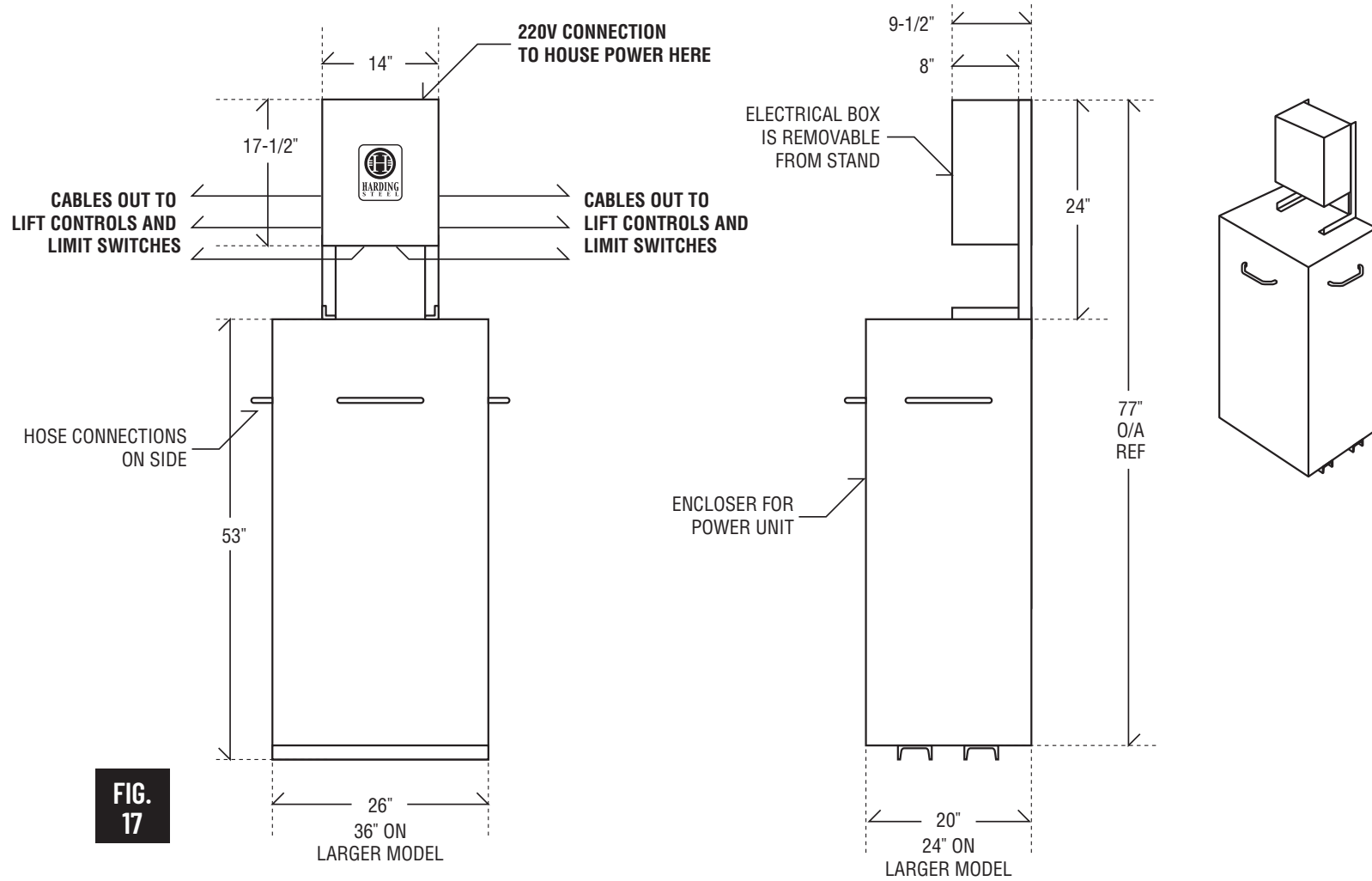
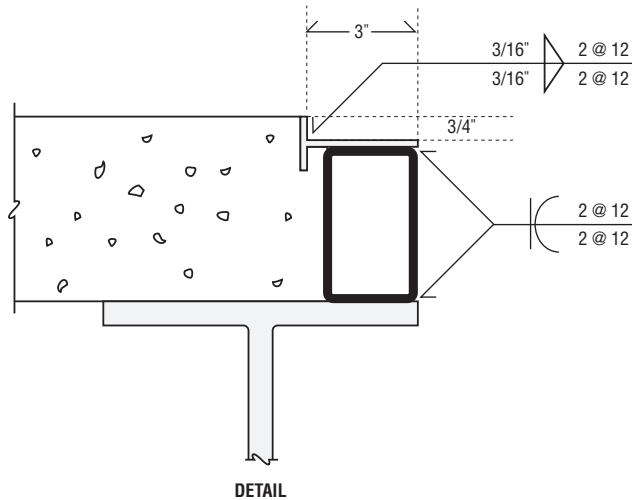
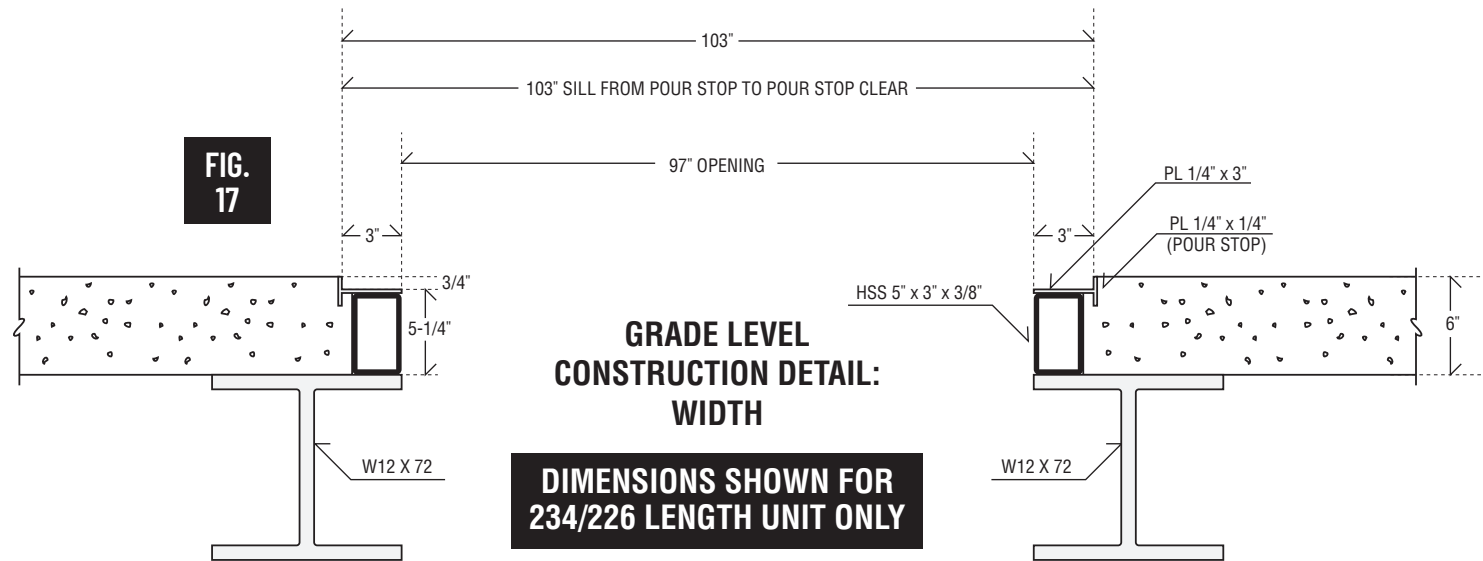

FIG.
16



EDGE DETAIL SAMPLE USING
TUBE STEEL OVER STRUCTURAL BEAM



EDGE DETAIL SAMPLE USING
TUBE STEEL OVER STRUCTURAL BEAM

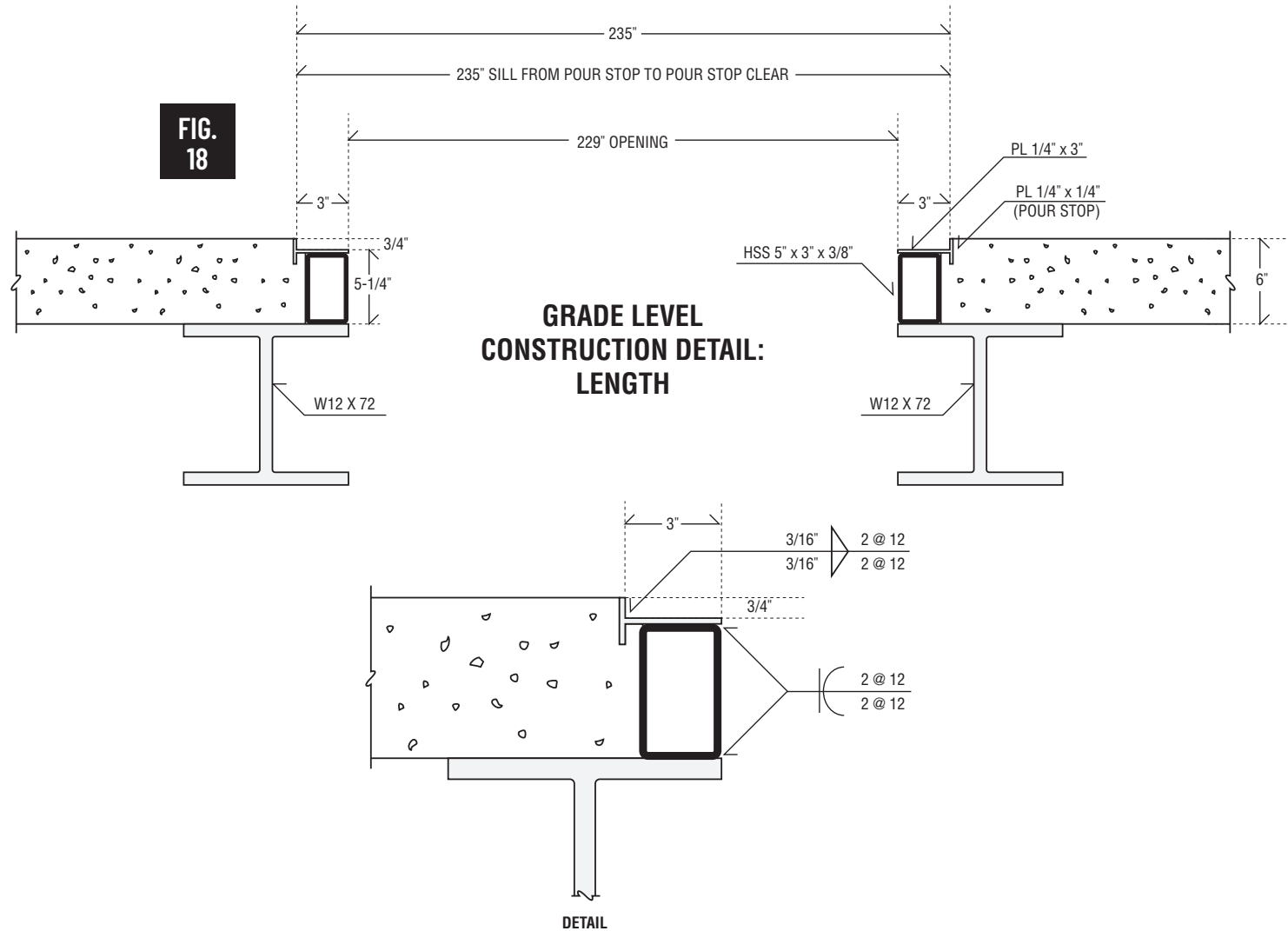

CARPARX™ VTS-2

FEATURES

- 100% premium steel construction
- Commercial grade design and materials
- Single, high-capacity scissors architecture for unsurpassed stability
- Four high-capacity hydraulic cylinders
- Lower level transport platform can move vehicles weighing up to 7500 pounds.
- Telescoping upper level platform creates a protective steel plate over the opening in the garage floor that will also support a vehicle weighing up to 6000 pounds for day-to-day parking.
- Suitable for indoor installation
- 220V high flow hydraulic power pack and controls
- Oversized all diamond-plate steel platforms handle full size SUVs and trucks
- Quality epoxy paint finish throughout with galvanized platform option

SAFETY

- Platform is free of all trip hazards, pit gaps, or protruding columns
- Key-operated control switches for security and safety
- Hydraulic velocity fuses on all cylinders
- Automatic shut-off if operator releases the key-switch
- Wiring block for integrating safety interlock devices
- Optional ceiling sensor kit available
- Seismic certified in the State of California
- Transport systems in commercial buildings must be properly enclosed and/or gated for safe operation.

POWER

208-220V Single Phase 80 amp

3-phase, high cap city pump available for commercial installations

208-220V Threephase for lifting multiple vehicles

All measurements are subject to change with final shop drawing.

VTS-2 STANDARD DIMENSIONS

Carparx Model	Length Designation	Upper Platform Length	Lower Platform Length	Upper Platform Width**	Lower Platform Width**	Grade Level Opening	Mini Pit Dimensions	Maximum Floor to Floor*	Interplatform Spacing*	Vehicle Weight
VTS-2 Extra Long	242/234	242"	234"	102"	94"	97" x 237"	97" x 237" x 25"	156"	78"	6000 lbs
VTS-2 Standard	234/226	234"	226"	102"	94"	97" x 229"	97" x 229" x 25"	144"	78"	6000 lbs
VTS-2 Short	226/218	226"	218"	102"	94"	97" x 221"	97" x 221" x 25"	132"	78"	6000 lbs
VTS-2 Extra Short	218/210	218"	210"	102"	94"	97" x 213"	97" x 213" x 25"	132"	78"	6000 lbs

* All dimensions subject to final shop drawings. ** Basement depth can be increased by the addition of height adjusting pedestals. Optional. Vehicle weight limit is for lifting cars on the lower platform only. Two-car lifting option available on all models.