

HARDING
AUTOPARK SYSTEMS



SPEC SHEET

COMBILIFT
543-2.0

**WÖHR
COMBILIFT
551-2.0**

Independent Access Parking for
Two-Car Stacking

COMBILIFT
551-2.0

Suitable for condominium and office buildings.
For permanent use only!

In case of short-term users (e.g. for offices, hotels, a.s.o.) technical adjustments are required. Please contact Harding Autopark Systems.

Load per platform max. 4400 lbs. (load per wheel max. 1100 lbs.)

Special reinforced units for heavier vehicles are available (see 541-2.6)

X = To be clarified with door supplier

Dimensions in inches.

** see notes, point 6

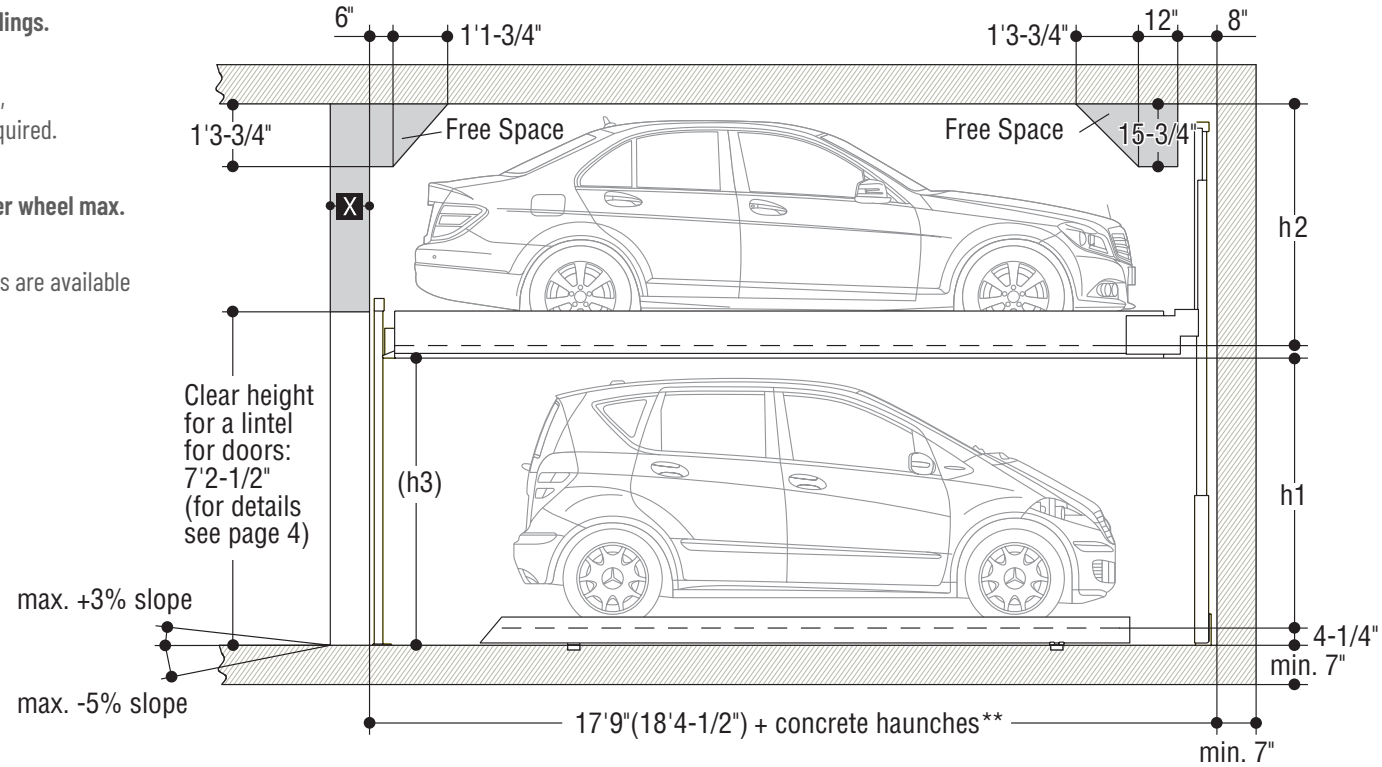

Standard Type 551 · 2000 kg

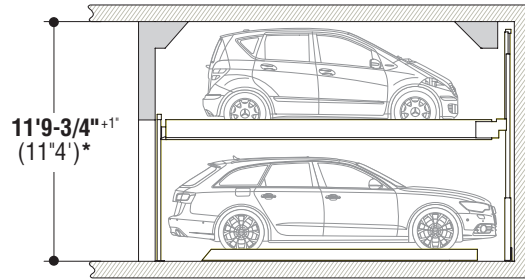

	CAR HEIGHT	DISTANCE
UL	Cars/Station wagons up to 5'5"	h2 = 5'6"
EL	Cars/Station wagons up to 5'5"	h1 = 5'7"

UL = Upper Level
EL = Entrance Level

Access height h3 = 5'11-1/4"

* If cars and station wagons with a height of up to **4'11"** are parked on the upper level, a clear height of **11'4"** above the entrance level is sufficient.

Comfort Type 551 · 2000 kg

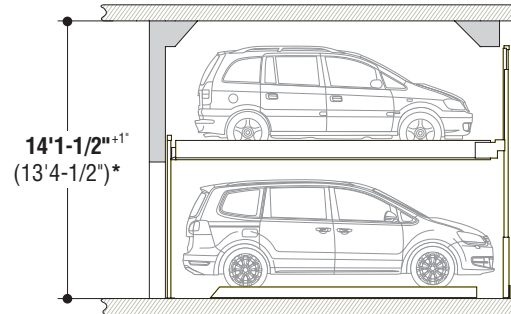

	CAR HEIGHT	DISTANCE
UL	Cars/Vans up to 6'6-3/4"	h2 = 6'8"
EL	Cars/Vans up to 6'6-3/4"	h1 = 6'8-3/4"

Access height h3 = 7'1"

* If cars and vans with a height of up to **5'9"** are parked on the upper level, a clear height of **13'3-1/2"** above the entrance level is sufficient.

Compact Type 551 · 2000 kg

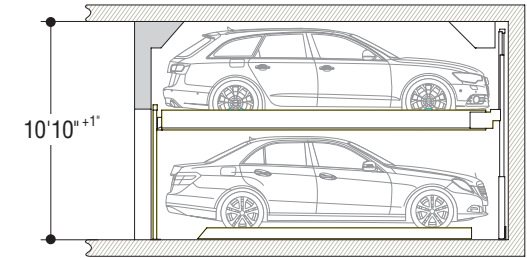

	CAR HEIGHT	DISTANCE
UL	Cars/Station wagons up to 4'11"	h2 = 5'1/4"
EL	Cars/Station wagons up to 4'11"	h1 = 5'1"

Access height h3 = 5'5-1/2"

Please pay attention to restricted car- and platform distance height!

Width Dimensions

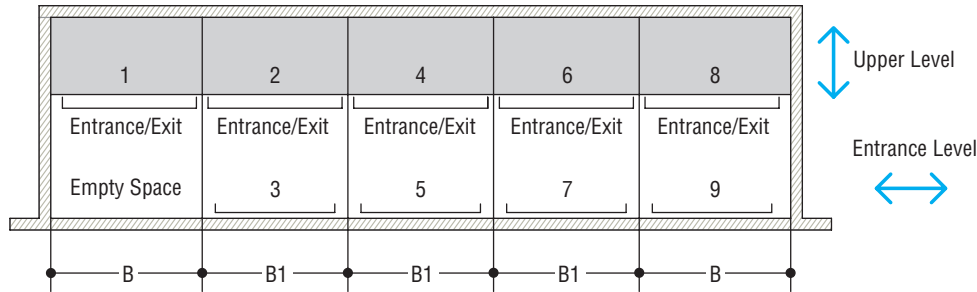

In each grid a entrance/exit is necessary.

Notes

1. For standard version no doors are necessary. Doors can be installed either for manual or automatic opening.
2. Arrangements start with 2 grids for 3 cars, 3 grids for 5 cars.
3. Installation length of 17'8-1/2" for car length of a max. of 16'5". Clear platform width of 8'2-1/2" for car widths of 6'3". For large touring sedans we recommend a clear platform width of at least 8'6-1/2"–8'10-1/4".
4. For large touring sedans an installation length of 18'4-1/2" is recommended. This length offers larger safety distances for potential future developments or projects with short term parkers such as hotels or similar.
5. In front of each grid a 4" wide, yellow-black marking according to ISO 3864 has to be provided by the purchaser (see "statics and construction requirements" on page 6).

SPACE REQUIRED B	GIVES CLEAR B1	GIVES CLEAR PLATFORM WIDTH UL	GIVES CLEAR PLATFORM WIDTH EL
8'6-1/2"	8'2-1/2"	7'6-1/2"	6'9-1/2"*
8'10-1/4"	8'6-1/2"	7'10-1/2"	7'1-1/2"*
9'2-1/4"	8'10-1/4"	8'2-1/2"	7'5-1/4"*
9'6"	9'2-1/4"	8'6-1/2"	7'5-1/4"*
9'10"	9'6"	8'10-1/4"	7'5-1/4"*

* The space to get in and out of the car for platforms in entrance level is increased by 1'1-3/4" driver side.

6. It is not possible to have channels or undercuts and/or concrete haunches along the intersection joints connecting the floor and the front building support columns and along the floor-to-rear wall joints. In the event that channels or undercuts are necessary, the total installation length needs to be increased based on the dimensions of said channels or undercuts.
7. The manufacturer reserves the right to construction or model modifications and/or alterations. Furthermore, the right to any subsequent part modification and/or variations and amendments in procedures and standards due to technical and engineering progresses in the art or due to environmental regulation changes, are also hereby reserved.

Doors

Combilift 551 must be closed with shutterdoors. The door controls are integrated in the overall system. That means:

- The doors are electro-mechanically interlocked.
- The doors can only be opened when the selected parking place has reached the entry/exit position.

Local requirements for electrical doors regarding the technology, maintenance and revision are not subject of our delivery. These matters have to be observed and carried out by the customer, according to the local regulations.

DOOR TYPES:

Manually operated sliding shutterdoors

- for underground garages with galvanised barred metal panelling
- above ground with powder coated metal sheets (RAL 7030)

Alternatively, sliding shutterdoors can be supplied with electrical drive.

Installation:

Behind the building pillars with door offset

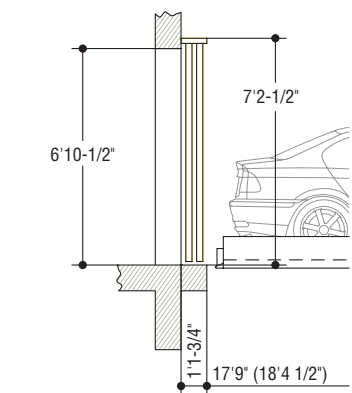

GROUND PLAN

- = 10" for manually operated sliding shutterdoors
- = 1'1-3/4" for automatic shutterdoors

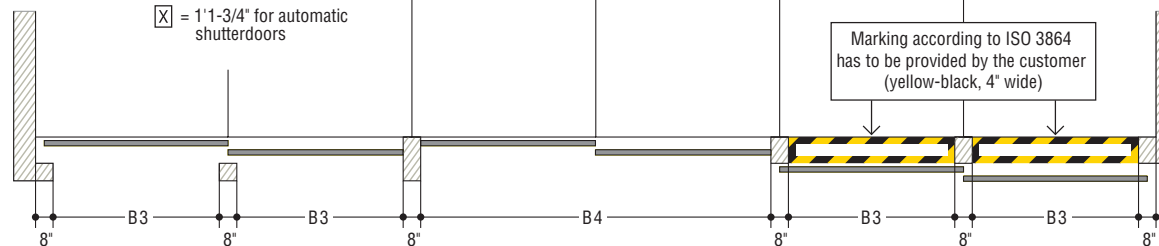

Installation:

Below the lintel between the building pillars

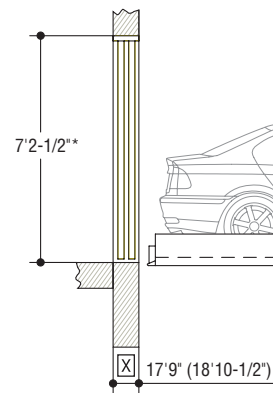

Installation:

In front of the building pillars

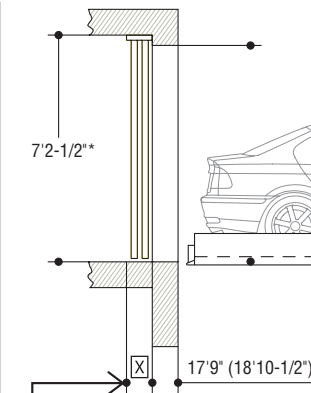

With installation in front of the pillars, the driving aisle is measured from the door.

Marking according to ISO 3864 has to be provided by the customer (yellow-black, 4" wide)

SPACE REQUIRED		GIVES CLEAR PLATFORM WIDTH
B3	B4	
7'6-1/2"	15'9"	7'6-1/2"
7'10-1/2"	16'5"	7'10-1/2"
8'2-1/2"	17'1/2"	8'2-1/2"
8'6-1/4"	17'8-1/2"	8'6-1/4"
8'10-1/4"	18'4-1/2"	8'10-1/4"

* The lintel of 7'2-1/2" is absolutely necessary. With differing heights, additional fixings are required at a surcharge. If no lintel is provided, the gates need to be fitted onto a steel frame (subject to surcharges).

Sliding Door Floor Guides in Underground Garages

The evenness or flatness of the floor in the bottom floor guide section is required to comply with ASTM FL25 standard requirements.

The bottom floor guides are composed of plastic rollers, locked down onto floor mounted base plates.

Anchor depth to be approx. 3-1/2".

Note: In the event that floor filling needs to be laid into the door section to the purpose of reaching the required floor evenness, the borehole depth needs to be increased by the thickness of the floor fill (for a max of 1-1/2").

FRONT VIEW

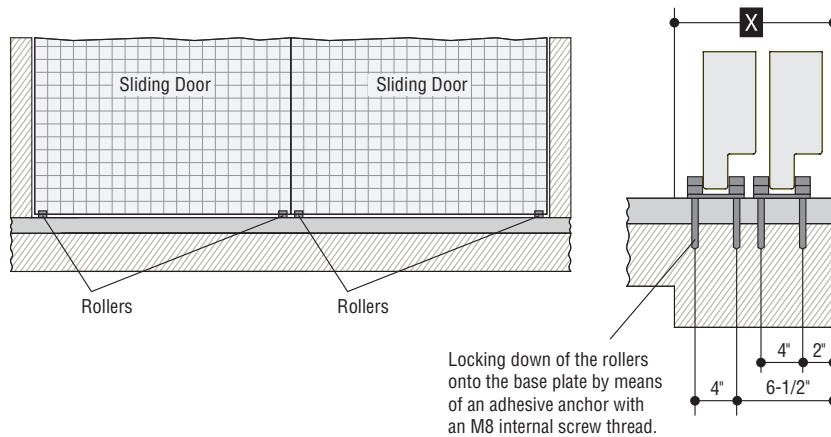

Sliding Door Floor Guides in Above Ground Garages

The evenness or flatness of the floor in the bottom floor guide section is required to comply with ASTM FL25 standard requirements.

The bottom floor guides are composed of guide rails, locked down onto the floor.

Anchor depth to be approx. 3-1/8".

Note: In the event that floor filling needs to be laid into the door section to the purpose of reaching the required floor evenness, the borehole depth needs to be increased by the thickness of the floor fill (for a max of 1-1/2").

FRONT VIEW

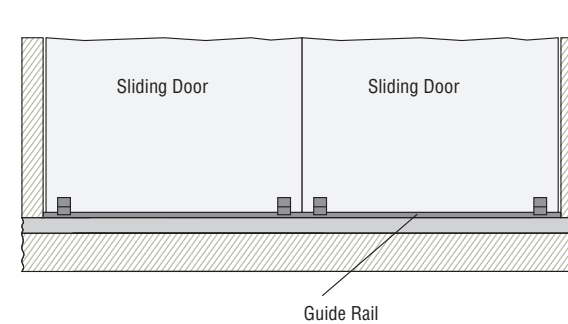

SECTION

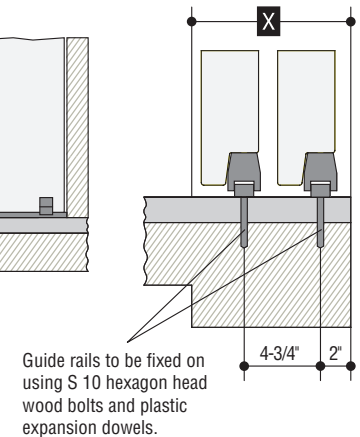

Evenness Tolerances

Floor flatness should exceed ASTM FL25 specifications.

Check Points

The evenness of a surface is checked independently of its position and slope by bore hole gauges between two check points on the surface. Harding Autopark Systems normally make a random test using single measurements in case of obviously inaccurate surfaces.

A) LAYOUT FOR SURFACE RECESS WIDTH 13'1-1/2"

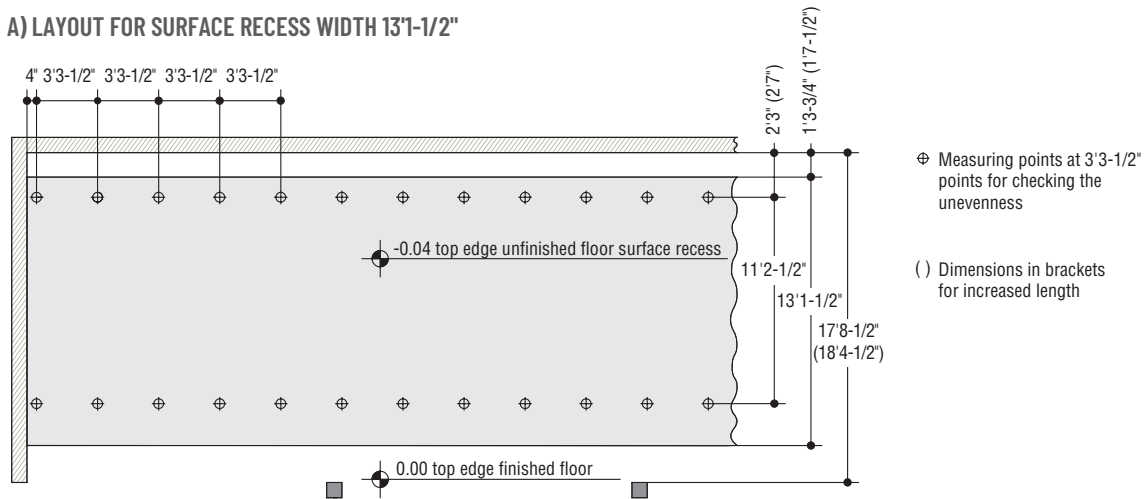

B) LAYOUT FOR FINISHED FLOOR AFTER PLACING FLOOR PAVEMENT

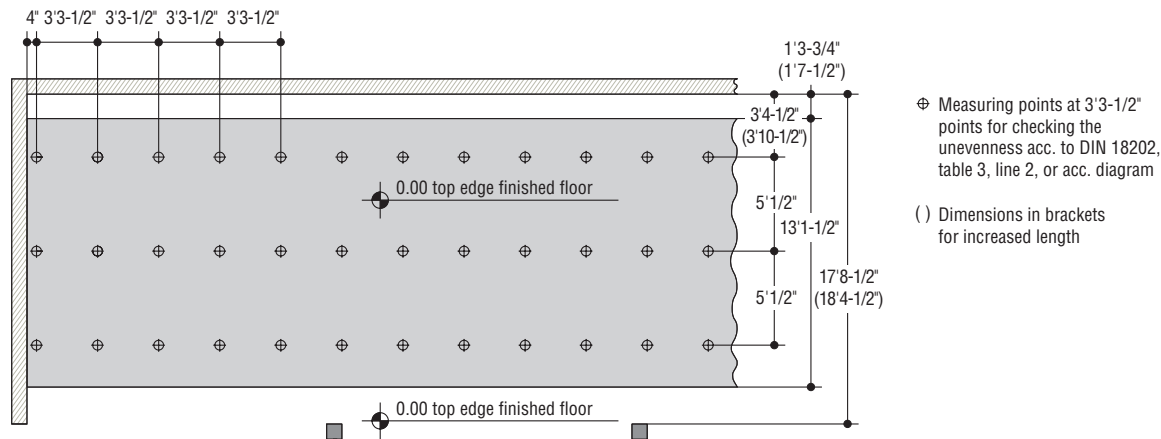

Track Installation · Flooring Works · Drainage

Track may either be surface mounted or recessed as shown below. The moving rail load of each platform wheel is max. 6 kN.

The evenness of the floor + screed must be achieved. After checking the floor + screed the levelling rails are mounted on top of the highest point.

The underlining and fixing of the levelling rails occurs at the intended fixing points. The screed is to be peeled off by the client on height of the levelling rails. Do not use mastic asphalt.

The running and guide rails are fastened after placement of the screed with bolts.

In the area of the railway track no expansion gap or building dividing gaps are allowed.

Due to the technical requirements there is no drainage fall allowed in the area of the system.

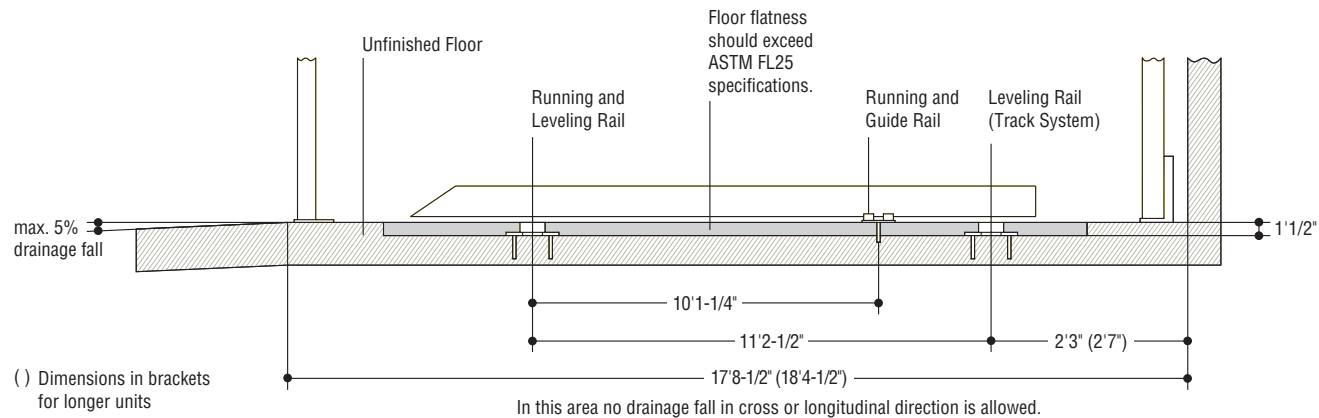

Width Dimensions and Statics

All dimensions shown are minimum. Constructional tolerances must be taken into consideration. All dimensions in feet and inches.

SECTION

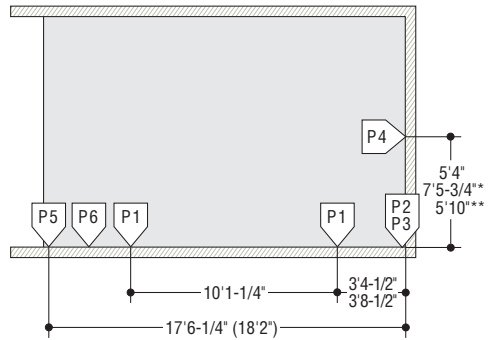

() Dimensions in brackets for longer units

* Dimensions for comfort type

** Dimensions for compact type

P1 =	+ 6,0KN ¹
P2 =	-10,0KN
P3 =	+25,0KN
P4 =	± 1,0KN
P5 =	+ 9,0KN
	- 7,0KN
P6 =	- 1,0KN

1 All static loadings include the weight of the car

Bearing loads are transmitted by wall plates with min. 4.65^{m2} surface and to the floor by base plates with min. 54.25^{m2} surface.

Wall and base plates to be fixed by heavy duty anchor bolts to a drilling depth of 4" - 4-3/4". When fixing to the waterproof concrete floors chemical anchors are employed (to be advised by Harding Autopark Systems).

Base plate thickness min. 7". Rear wall and base plate must be formed of concrete and must have a flat surface without protrusions.

Concrete quality according to the static building requirements, however for the dowel fixing concrete quality of min. C20/25 is required.

The specified lengths to the support points are mean values. Please contact Harding Autopark Systems for exact positions for any variations on the standard units.

Please contact Harding Autopark Systems to clarify the door widths/widths of columns. Grid width of

GROUND PLAN

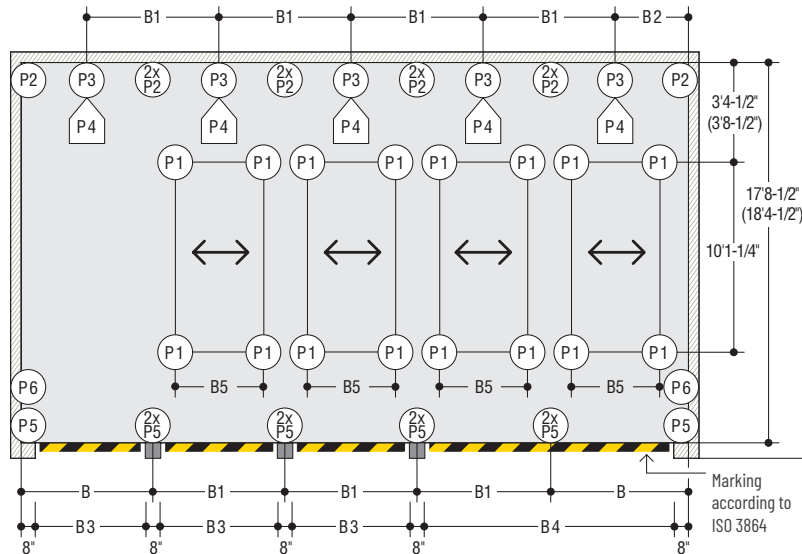

B	SPACE REQUIRED				GIVES CLEAR	
	B1	B2	B3	B4	EL (B5)	UL
8'6-1/2"	8'2-1/2"	4'5"	7'6-1/2"	15'9"	6'9-1/2"	7'6-1/2"
8'10-1/4"	8'6-1/2"	4'7"	7'10-1/2"	16'5"	7'1-1/2"	7'10-1/2"
9'2-1/4"	8'10-1/4"	4'9"	8'2-1/2"	17'3/4"	7'5-1/2"	8'2-1/2"
9'6"	9'2-1/4"	4'11"	8'6-1/2"	17'8-1/2"	7'5-1/2"	8'6-1/2"
9'10"	9'6"	6'1"	8'10-1/4"	18'4-1/2"	7'5-1/2"	8'10-1/4"

The driving aisle width to be compliant with country regulations locally in force.

HYDRAULIC POWER PACKS

The hydraulic power pack is positioned within the system.

SWITCH CABINET

The switch cabinet is positioned within the system at the rear wall.

ELECTRICAL DATA

Connection 208-230V, 50/60Hz, 3 Phase. power consumption max. 3.5 kW.
Fuse or circuit breaker 3 x 30A slow blow and supply line 3 Ph+N+PE (according to local regulations) up to the main switch, and connection of the supply line is performed by customer

Grounding and potential equalisation:

- to be performed by the customer compliant to DIN EN 60204
- connections required every 10 metres

GENERAL PRODUCT INFORMATION

The combilift Type 551 consists of 2 platform rows, one above the other. In front (to the full width) of the installations is a drive way which is situated on the lower platform row (access level). The lower platform row consists of one platform less than the upper level.

In order to access a platform on the upper level, the lower level platforms (access level) shift laterally into the free space. The selected upper platform is now lowered vertically into the free space provided in the access level.

HOTEL GARAGE

If used by hotel guests, the installation requires special planning and construction. Please ask for details.

TEMPERATURE

The installation is designed to operate between +5° and +40°C. Atmospheric Humidity: 50% at +40°C. If the local circumstances differ from the above please contact Harding Autopark Systems.

NUMBERING OF THE PARKING SPACES

1. The empty space of the Combilift is always on the left in the entrance level.
2. The numbering is as follows:

UL	1	2	4	6	8
EG		3	5	7	9

3. The numbering for each system starts with 1 as above.
4. Different numbering of parking spaces is possible at a surcharge (software changes are necessary).

CONFORMITY TEST

All our systems are checked according to EC machinery directive 2006/42/EC and EN 14010.

ILLUMINATION

Illumination has to be considered acc. to local requirements by the customer.

FREE SPACES

Special drawings for free spaces to accommodate air ducts or other pipes can be requested at Harding Autopark Systems.

RAILINGS

If walkways are arranged directly to the side or behind the systems, railings have to be provided by the customer acc. to local requirements, height min. 6'6-3/4" - this is applicable during the construction phase too.

MAINTENANCE

Preventative maintenance services available through Harding Autopark Systems.

PROTECTION AGAINST CORROSION

Independent of a maintenance workings has to be carried out acc. to Harding Autopark Systems

Cleaning and Maintenance Instruction regularly.

Clean up galvanized parts and platforms of dirt and road salt as well as other pollution (corrosion danger)!

PARKING PLACE WIDTH

We recommend a clear platform width of at least 8'2-1/2".

DIMENSIONS

All dimensions shown are minimum. Construction tolerances must be taken into consideration. All dimensions in inches.

FIRE SAFETY

Each and every fire safety requirement and all possible mandatory item(s) and equipment(s) (fire extinguishing systems and fire alarm systems, etc.) are to be provided by the customer.

CLEARANCE PROFILE (STANDARD SALOON/ESTATE CAR)

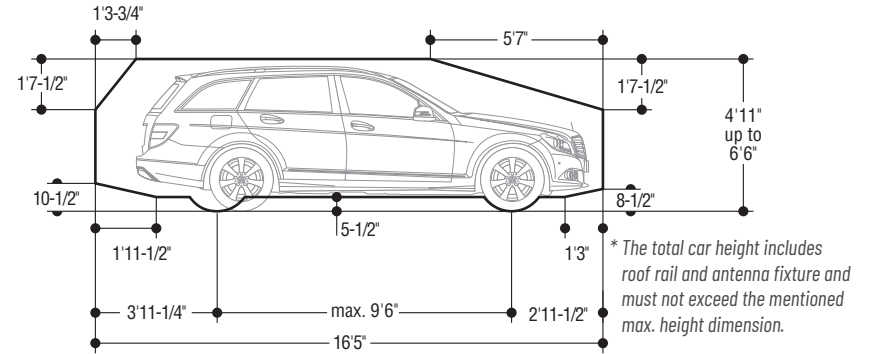

NOTES

If doors are planned we recommend installing an empty pipe for cabling to the control panel from the rear. This empty pipe should be 3'11-1/4" above ground level in the centre of a column.